

# TANK TUB INSTALLATION INSTRUCTIONS

**NEW TANK  
LEG SIZES with  
New LID!!!**

**IMPORTANT!!!** IF THIS IS YOUR FIRST INSTALLATION CALL CUSTOMER SERVICE FOR HELPFUL TIPS & SPEED UP YOUR INSTALLATION - CALL - 1 877 482-6562

- **BEFORE BEGINNING:** Tank Leg sizes now REQUIRE Tank Leg Flanges
- **NOTE:** You will need duct tape and a hole saw  
Hole Saw Drill Size **MUST BE 1/2"** larger than fill & vent pipe sizes used.
- **NEW:** PLACE OIL TANK IN TUB WITH THE LIFTING LUG FACING THE BACK OF THE BASIN. (the back has pilot holes for the oil lines)

**IMPORTANT:** CONSULT LOCAL CODES FOR INSTALLATION AND USE OF THIS PRODUCT. IN THE ABSENCE OF SUCH LOCAL CODE REQUIREMENTS, THE FOLLOWING ARE MINIMUM RECOMMENDED INSTALLATION AND USE GUIDELINES.

THIS PRODUCT IS INTENDED TO PROVIDE TEMPORARY SECONDARY CONTAINMENT AND ENVIRONMENTAL / PHYSICAL PROTECTION TO LISTED UL 80 OR 142 STEEL PRIMARY TANKS FOR ANY HEATING OIL OR OTHER PETROLEUM, CORROSIVE OR HAZMAT LIQUIDS OF MAX 330 GAL.

- 1.**
  - Installation surface must be level.
  - The surface must be capable of supporting a Tank Tub plus a full oil tank.
- 2.**
  - **VERY IMPORTANT: USA: USE 6" tank legs and MUST USE flanges**  
**CANADA: no larger than 4" tank legs WITH flanges**
  - Inspect tank: drain oil/water and inspect all seams for damage or corrosion.
  - Do not place damaged or leaking tanks in service.
  - Close bottom opening of tank with steel plug.
  - If thread sealants are required, use types which are rated for low temperatures, oil and other outdoor conditions.
- 3.**
  - Lay the Tank Tub on its side and, using **duct tape (not included)**, secure galvanized steel plates to Tub floor.
  - Stand tank and level legs on level ground.
  - Slide tank on its side into the Tub with the lifting lug facing the back of the Tank Tub installation; then stand the tank and Tub upright.
  - **Very Important: Ensure tank legs are sitting on steel plates inside the Tank Tub.**
  - **If using a 275 gallon tank, position the tank slightly closer to the end that the fill and vent exit the Tub lid.**



- 4.**
- The fill and vent exit on the same end. This enables you to lift the lid from the opposite end and view inside the Tub.
  - FOR FILL LINE: Use first tank tapping. Use two street elbows to make a swing joint. Then attach a 24" nipple. See picture below.
  - FOR VENT PIPING: Install the vent alarm in the 2<sup>nd</sup> tank tapping, then a street elbow into the vent alarm. Install a 6" nipple to the street elbow and then a 90 degree elbow and finish with a 36" pipe to complete vent alarm piping.
  - If you choose to use a combo vent/gauge alarm, 4" tank legs must be used instead of 6" legs.



BACK of tub

Piping illustration

In Maine: a thermal shut off valve must be installed at the tank.

Oil line illustration



- 5.**
- Refer to diagram above.
  - Due to Limited access to the bottom of the tank, the oil lines CAN ONLY be pulled from the top of the tank.
  - Drill appropriate size holes for your oil line exit holes out of Tub Basin. Suggested pilot holes are centered on the back-side of the basin. Do not drill above or too far below these points.
  - Install burner lines from the top of the tank through side holes. Route to burner away from heat sources or physical damage. Silicone exit holes for additional water resistance.

- 6.**
- Refer to photographs below.
  - Cut the holes for your fill and vent pipe. Use the pilot holes we have provided.
  - Use either a 2 5/8" or 3" hole saw. Do not silicone the gap around the pipe. There should be at least a 1/4" gap around the fill and vent pipe. (This allows the lid to open freely from the opposite end.)
  - From the gasket kit, roll the o-rings over the fill and vent pipes. Rest them between the inside and outside layers of the lid.



Cut holes with hole saw 1/2" larger than piping.



**PLEASE REFER TO STEP #7 FOR SLIDING LID INTO POSITION.**

# TANK TUB

## Piping Example: Fill & vent installation

### VENT SETUP

VENT ALARM  
STREET ELBOW  
6" PIPE  
ELBOW  
(1) 36" PIPE or (2) 18" PIPE

### FILL SETUP

(Swing Joint)  
(2) STREET ELBOW  
24" PIPE

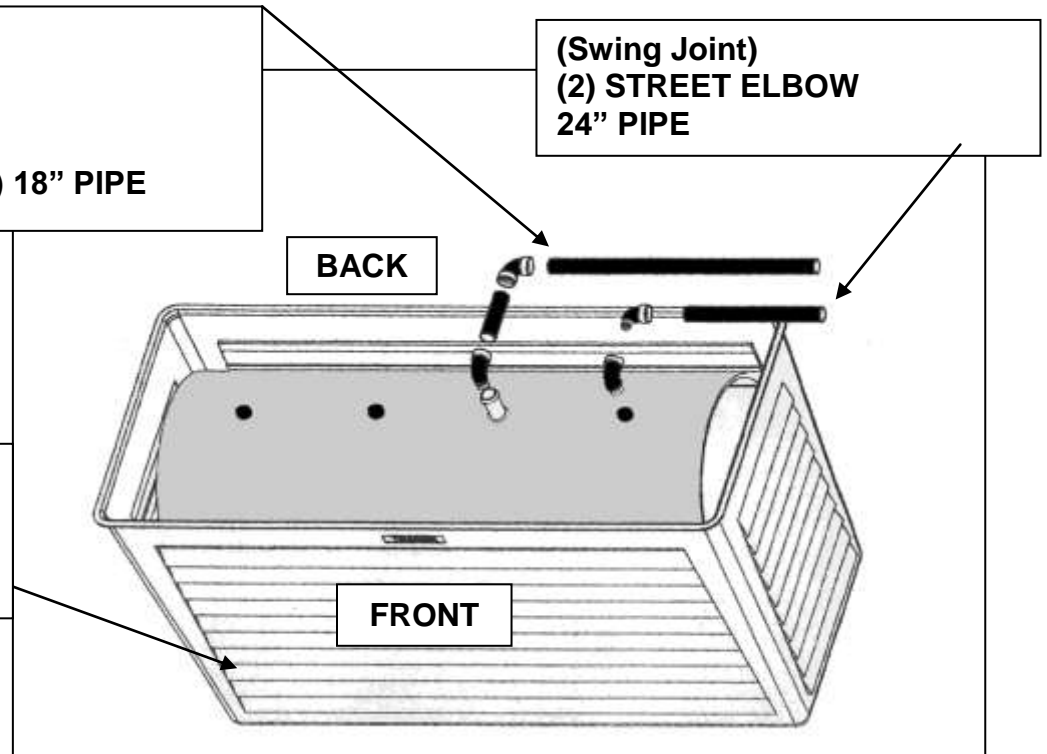

### TANK LEG SETUP

USA: 6" Tank Legs AND  
MUST USE Flanges as well.

Canada: No greater than 4".

### LID INSTALLATION

7. A. Two Installers bring the lid over the Tank Installation.
- B. Set the end of the lid with the holes made for the piping beyond the basin.
- C. The second installer raises the other end as the installer on the piping end feeds the fill and vent through the inner and outer holes.
- D. The cover is then pushed over the piping and placed into position.
- E. The O rings should be set in place on both pipes inside the lid walls.
- F. After lid is installed, install the proper vent cap and fill box.

